

AN EXPERIMENTAL STUDY ON CWM COMBUSTION IN FLUIDIZED BED COMBUSTOR

J.O. Chae*, T.Y. Chung** and S.K. Oh***

(Received August 25, 1989)

In this study, CWM is combusted and combustion phenomena are investigated in fluidized bed combustor which has 140mm I.D. and 2300mm height. The bed material is sand of mean diameter 0.405mm and fixed bed height is 200mm. CWM is injected either over-or in-bed through water-cooled injector by positive displacement pump. The exhaust gas composition, the elutriation rates, and the unburned carbon contents in elutriated ash are measured. The combustion efficiencies are also investigated according to the CWM injector locations, excess air ratios, and air preheat temperatures. When CWM injector is used, the combustion of CWM is proceeded in agglomeration condition regardless of the CWM injector positions. The contents of unburned carbon and the elutriation rates are lower for the case of over-bed injection than for in-bed injection. And the combustion efficiencies according to the excess air ratios show the same tendency regardless of the positions of CWM injector, when the fluidizing velocities are low.

Key Words : CWM, Fluidized Bed Combustion, Combustion Efficiency

1. INTRODUCTION

The coal-water mixture(CWM) has been used as a substitute fuel for B-C boiler with the development of CWM technology (Philipp, 1984). The reason is, because CWM is not only convenient of transportation, but also friendly for air pollution.

Because CWM has low viscosity compared with B-C oil, it can be transported long distance through pipeline. And it is cleaner than the coal because CWM does not produce any dust in storage(Cen, 1985).

In order to utilize the CWM as a substitute fuel for B-C oil, CWM must be atomized by twin-fluids method(Kim, 1984). When twin-fluids method is applied for the atomization in retrofitted B-C boilers, CWM erodes the atomizing nozzle, as it passes through the nozzle. Meanwhile, the preheating time of the retrofitted B-C boilers is long. Such demerits are the bottleneck to be solved, when the CWM is utilized by the conventional twin-fluids method.

Recently there has been another effort to overcome the demerits by way of the fluidized bed combustion. The fluidized bed combustion allows the versatility of fuels including the CWM with high water contents.

In order to feed the CWM into fluidized bed combustor, the method of twin-fluid atomization (Arena, 1984; Rowley, 1985) and that of dropping at free board (Cen, 1986) are used. In case of twin-fluid atomization CWM forms agglomeration and deposits on the air distributor, when the size of agglomeration becomes bigger than that of fluidizing material. However, in case of dropping at free board, it does not deposit on

the air distributor, although CWM is combusted in agglomeration condition.

In Cen's study (1985 and 1986) only one feeding point of CWM is investigated, in spite of the fact that the feeding points could influence the combustion phenomena significantly.

In this study, CWM is injected either over-bed or in-bed through water-cooled injector by positive displacement pump.

Other parameters including excess air ratio, fluidizing velocity, and air preheat are investigated for the combustion of CWM in the fluidized bed combustor, which has 140mm inner diameter and 2300mm height.

2. EXPERIMENTAL EQUIPMENT AND METHOD

2.1 Experimental Equipment

The experimental installation consists of combustion air supply apparatus, air preheater, fluidized bed combustor, bed temperature control system, CWM feed system, dust collect and exhaust gas sampling system, and exhaust gas analyzer. Fig. 1 shows a schematic diagram of experimental apparatus.

Combustion air is supplied by roots blower, of which maximum pressure and maximum free air delivery rate are 1.0kg/cm² and 5m³/min respectively.

Two surge tanks are installed at the blower outlet to prevent the air pulsation. The flow rate of combustion air is controlled by globe valve and measured by orifice flowmeter.

In order to preheat combustion air, two air preheaters with 5kw electric heaters are installed inside the cylinder of 600mm diameter and 600mm length between orifice flowmeter and air plenum of fluidized bed combustor.

The fluidized bed combustor of 140mm in inner diameter and 2300mm height consists of air plenum, air distributor, combustion chamber, and free board.

The air distributor is perforated type, whose opening area is 0.89%.

*Department of Mechanical Engineering, Inha University, Incheon 402-751, Korea.

**Department of Mechanical Engineering, Kookmin University, Seoul 136-702, Korea.

***Korea Gas Safety Corporation, Shihung 421-900, Korea.

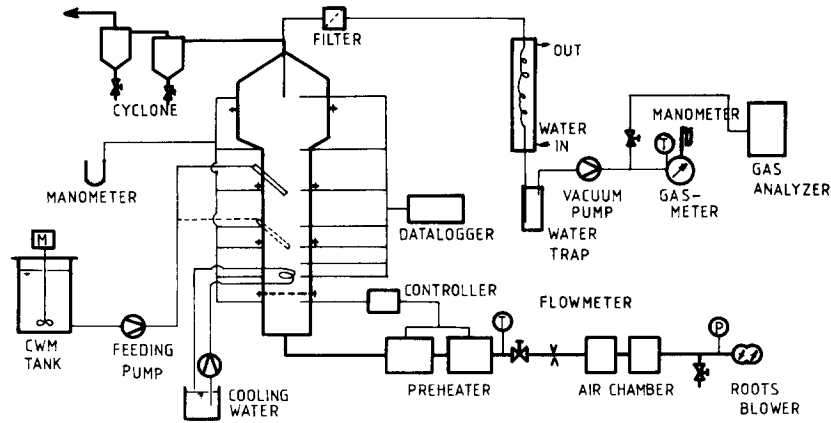

Fig. 1 Schematic diagram of experimental apparatus

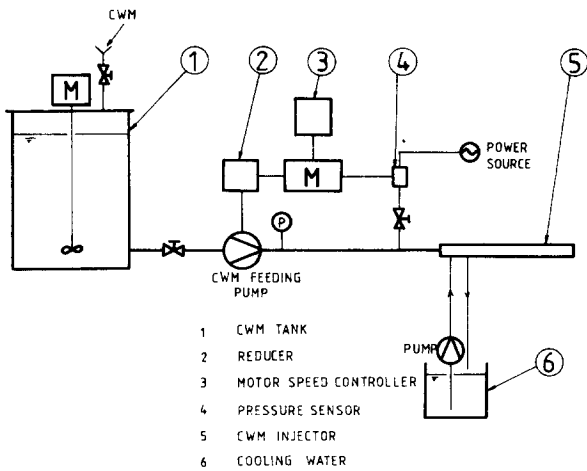

Fig. 2 Schematic diagram of CWM feeding apparatus

In order to control bed temperature, the cooling water is supplied through the stainless steel tube of 6.35mm diameter which is located in the fluidized bed.

Figure. 2 shows a schematic diagram of CWM feed system. It consists of CWM tank with agitator, flexible tube, positive displacement pump connected with variable speed motor and speed reducer, and water-cooled CWM injector.

The water cooling of the CWM injector is necessary to prevent the getting blocked, when it is inserted in the hot bed condition. The injector locations are 350mm and 700mm above the air distributor respectively. The feeding point 350mm above the air distributor corresponds to in-bed injection of CWM, while the other corresponds to over-bed injection.

The isokinetic sampling probe is installed vertically in the free board to collect flying ash. Fig. 3 is a schematic diagram of exhaust gas sampling system, which consists of water cooled isokinetic sampling probe, dust filter, filter holder, vacuum pump, gas meter, and gas analyzer.

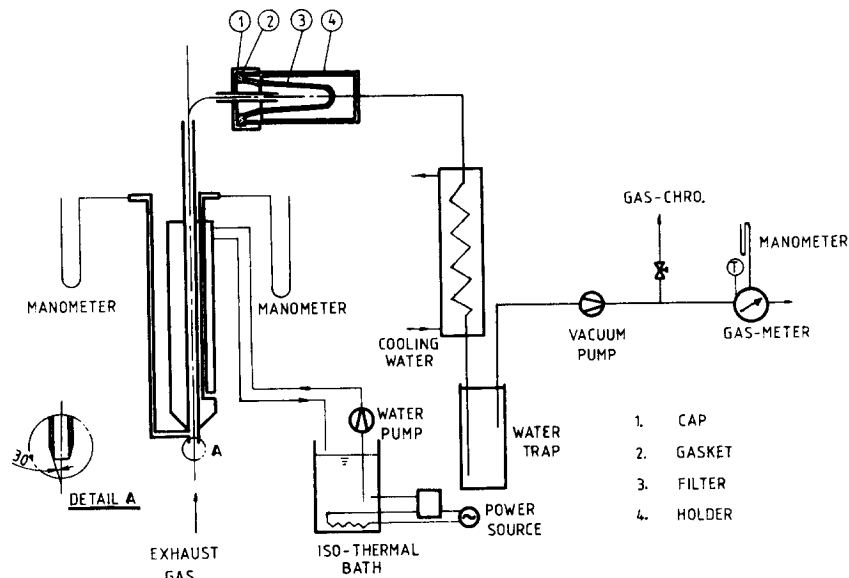

Fig. 3 Schematic diagram of exhaust gas sampling apparatus

cooling bath, vacuum pump, and gas-meter. As gas analyzer for CO, CO₂, O₂, CH₄, and H₂ gas-chromatograph is used.

Two cyclone collectors are installed in series to stack to prevent the air pollution.

2.2 Experimental Method

For the experiment, the CWM of 63.5wt.% coal and 36.5wt.% water which is provided KIER(Korea Institute of Energy & Resources) is used. The properties of the coal in the CWM and CWM itself are shown in Table 1 and Table 2 respectively. The coal particle size in the CWM is very fine, as shown in Table 3.

The bed material is sand of mean diameter 0.405mm and the fixed bed height is 200mm. The size distribution of sand is shown in Table 3.

For the ignition of CWM temperature of the air preheater is set at 150°C, while bed material is kept fluidizing at around minimum fluidizing velocity. A gas burner is used to raise the bed temperature. The CWM is injected into the combustor, when the bed temperature is reached about 400~500°C. As the bed temperature goes up to about 850°C, the gas burner is extinguished.

The fluidized bed temperature is regulated by cooling water, which is circulated through stainless tube located in bed.

Table 1 Properties of coal

Proximate analysis	Moisture (%)	4.1
	Ash (%)	12.51
	Volatile matter (%)	33.25
	Fixed carbon (%)	50.14
Ultimate analysis	Carbon (%)	69.03
	Hydrogen (%)	4.36
	Nitrogen (%)	0.35
	Sulfur (%)	0.17
	Oxygen (%)	13.04
	Ash (%)	12.51
	Total	100
Higher calorific value (kcal/kg)	6,810	
Fuel Ratio	1.5	

Table 2 Physical properties of CWM

Component	63.5wt.% : Coal 36.5wt.% : Water
Viscosity	840cp(Brook field viscometer)
Particle size	200mesh pass 79.5% 325 mesh pass 70.9%

Table 3 Size distribution of sand

Mesh	Diameter, d_p (mm)	Weight fraction, x	Cumulative(%)
16~20	1.01	0.056	5.6
25~30	0.65	0.222	27.8
35~40	0.46	0.489	76.7
45~50	0.324	0.178	94.5
80~120	0.15	0.044	98.9
140~325	0.066	0.011	100

$$\bar{d} = \frac{1}{\sum \frac{x}{d_p}} = 0.405\text{mm}$$

In order to change the excess air ratio, the feed rates of the CWM are varied by a special pump coupled with a variable speed motor, while combustion air is supplied at fixed flow rate.

The gas sampling probe should be operated at the isokinetic condition to guarantee the same particulate condition in the sampling gas as that in the combustion gas of the combustor. The isokinetic condition is achieved, so long as the static pressures at the inner and outer surfaces of the sampling probe are kept equal. While it is being sampled, the carbon in the sampling gas could be burned, because the temperature is high. Therefore, the sampling gas should be quenched as low as ignition temperature of coal by cooling water.

The combustion efficiency (η_c) is defined as follows (Water, 1975; Poersch 1979);

$$\eta_c = \frac{C_i \times M_s - C_f \times M_f - C_b \times M_b - C_c \times M_c}{C_i \times M_s} \quad (1)$$

where.

C_i : equivalent carbon content of the fuel

C_b : carbon content of drained ash

C_c : carbon content of flue gas

C_f : carbon content of elutriated ash

M_b : flow rate of drained ash

M_c : flow rate of flue gas

M_f : flow rate of elutriated ash

M_s : flow rate of fuel

3. EXPERIMENTAL RESULT AND DISCUSSION

3.1 CWM Combustion in Fluidized Bed Combustor

In the experiment the CWM is fed into the combustor just like running water by the CWM injector, as shown Fig. 4. It is very different point from the conventional atomization.

The combustion phenomena of CWM with the water-cooled injector, therefore, are different from that of twin-fluid injector method, where the CWM is atomized (Arena, 1985).

In Fig. 5 CWM agglomeration is shown, when the CWM injector is located over-bed. The Fig. 6. shows the case of in-bed injection.

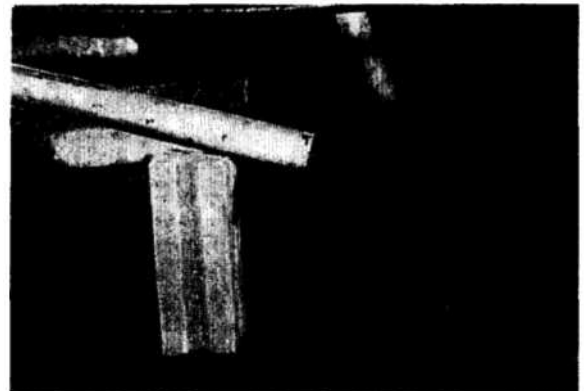

Fig. 4 Pattern of CWM Injection

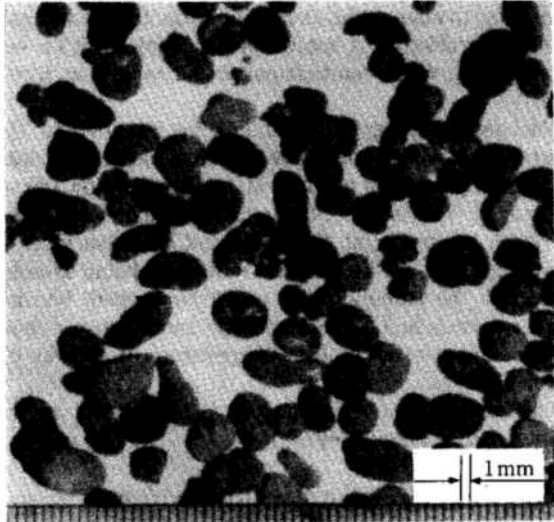

Fig. 5 CWM agglomerat (injector position:over-bed)

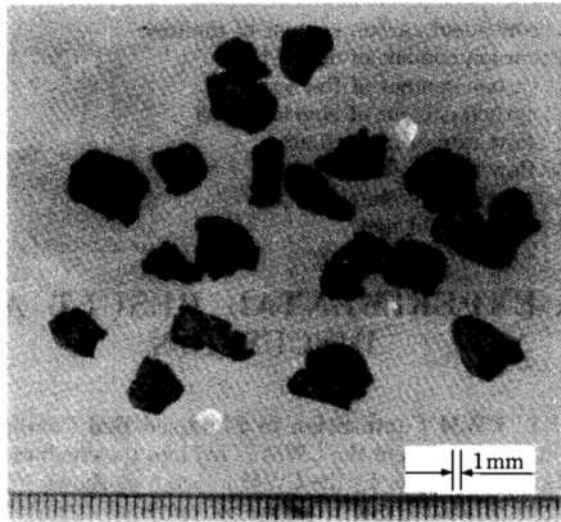

Fig. 6 CWM agglomeration (injector positon : in-bed)

The size of the agglomerations for in-bed injection are larger and more irregular than those of over-bed injection. The average size for both feeding points are 4.8mm and 7.6mm respectively.

The strength of agglomeration of in-bed is weak and the agglomeration is very brittle. It is estimated that high heat transfer from the bed material to in-bed agglomeration could cause fast evaporation of water from the CWM to make the agglomeration brittle. Meanwhile the agglomeration of over-bed injection is in the smooth shape and very hard. In any case, however CWM is combusted in agglomeration regardless of the CWM injector position. It is presumed that the combustion of the CWM is proceeded as shown in Fig. 7. CO_2 is produced from the combustion of volatile matter from the surface of agglomeration or char (Patricia, 1984). The char is changed to dry fines (Beer, 1985) due to combustion and wear. And dry fines are elutriated to stack.

3.2 Unburned Carbon Content in Elutriated Ash

Fig. 8 shows the unburned carbon contents in the elutriated

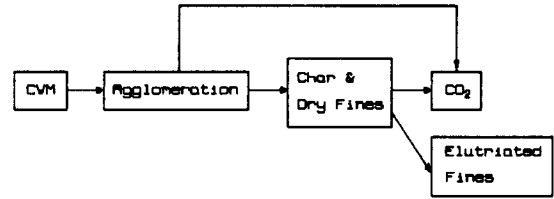

Fig. 7 Combustion process of CWM using CWM injector in fluidized bed combustor

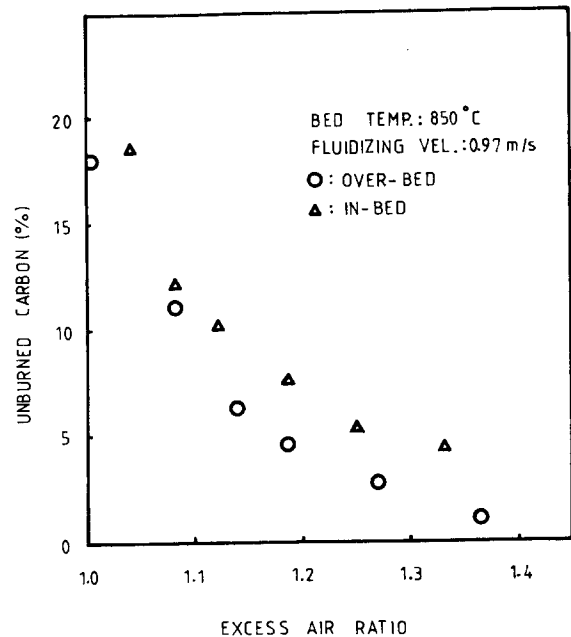

Fig. 8 Unburned carbon in elutriated ash vs. excess air ratio

ash as the CWM injector positions are over-and in-bed. When the injector position is over-bed, the unburned carbon content is 18% at the excess air ratio of 1.01, while it is 2% at the excess air ratio of 1.37. When the injector position is in-bed, the unburned carbon content is 18.5% at the excess air ratio of 1.03, while it is 4.7% at the excess air ratio of 1.34. As excess air ratio increases, the unburned carbon contents in elutriated ash decrease drastically. The unburned carbon content is lower at high excess air ratio when injector position is over-bed. The reason is probably because the agglomeration strength for in-bed injection is more brittle than that for over-bed injection and the residence time for over-bed injection in fluidized bed is longer than that of in-bed injection.

3.3 Elutriation Rates

In Fig.9 the effect of the excess air ratio on the elutriation rate is shown, when the CWM injector positions are over-and in-bed. The elutriation rate increases as the excess air ratio increases. In-bed injection has the higher elutriation rate than over-bed injection has at the same excess air ratio. This may be due to the fact that the agglomeration strength of in-bed injection is weaker than that of over-bed injection. That is, the agglomeration formed in-bed is more breakable.

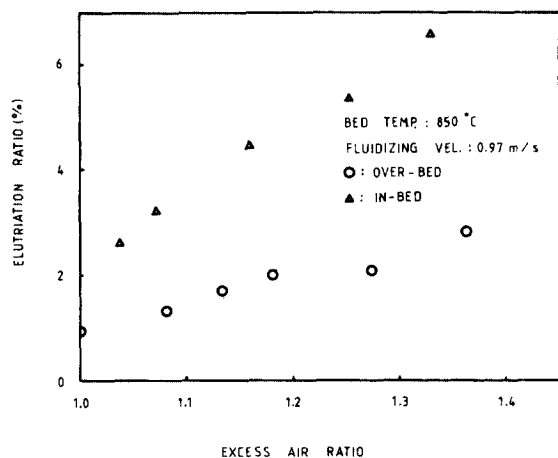

Fig. 9 Elutriation ratio vs. excess air ratio

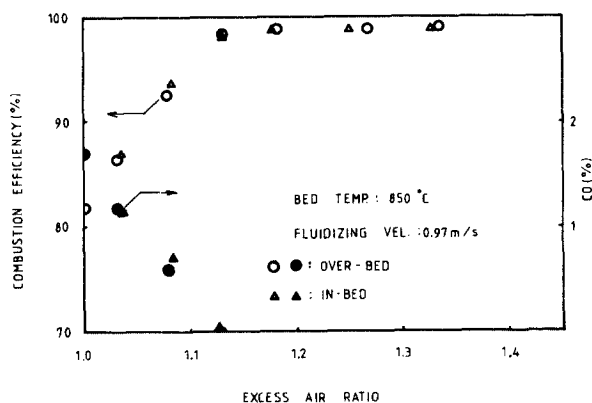

Fig. 10 Combustion efficiency vs. excess air ratio

3.4 Combustion Efficiency

In Fig.10 the combustion efficiency vs. the excess air ratio according to the injector positions is shown. As the excess air ratio is over 1.12 the combustion efficiency reaches 98-99% and remains almost constant. As shown in Fig.10, the excess air ratio is the very significant factor for the combustion efficiency. It is also shown that the feeding points of the CWM do not make any considerable difference to the combustion efficiency. In the range of low excess air ratio below 1.12, the bad combustion efficiency is mainly due to the in-complete combustion gas, namely CO. The effect of unburned CO gas on the combustion efficiency is more dominant than the effect of unburned carbon in the elutriated ash, especially when the elutriation rate is not so significant in the low range of fluidizing velocity.

3.5 Effect of Combustion Air Temperature on Combustion Efficiency

For studying the effect of combustion air temperature on the combustion efficiency, the experimental parameters are kept up constant as follows;

The average bed temperature is 850°C, the excess air ratio 1.12 and 1.14, and the CWM injector position is fixed as over-bed.

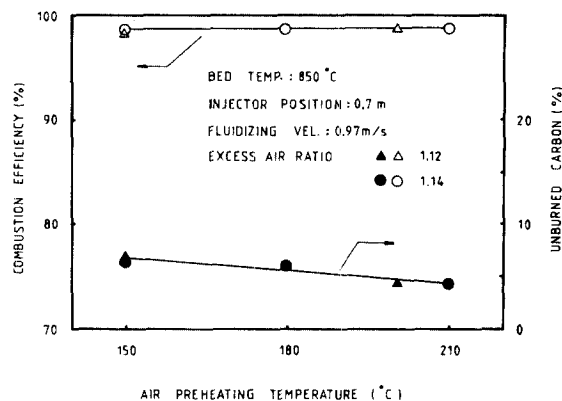

Fig. 11 Effect of air preheating temperature on combustion efficiency and unburned carbon in elutriated ash

In Fig. 11, the effect of air preheat temperature, combustion air temperature on combustion efficiency is shown. It is easily seen that the combustion efficiency is hardly changed, although the preheat temperature of combustion air is increased. Meanwhile the unburned carbon in the elutriated ash is decreased, according to the air preheat temperature. However, it does not influence the combustion efficiency much, because the elutriation ratio of ash is neglectable.

In this study, the minimum preheat temperature of combustion air is 130°C to maintain the average bed temperature at 850°C, when the excess air ratio is 1.37 with over-bed injection. Therefore it could be concluded that the combustion air preheating is necessary to keep the combustion of the CWM with high water content in the steady operational condition, although it does not enhance the combustion efficiency considerably.

4. CONCLUSION

The combustion efficiency and combustion phenomena of the CWM with 63.5wt.% coal and 36.5wt.% water are investigated in the fluidized bed combustor which has 140mm I.D. and 2300mm height.

The CWM is injected just like running water, not the atomized condition either over-or in-bed through a water-cooled injector by positive displacement pump. The experimental results are as follows;

- (1) The combustion of the CWM is proceeded in agglomeration condition regardless of the CWM injector positions.
- (2) The contents of the unburned carbon in elutriated ash and the elutriation rates are lower, when the CWM injector is located at over-bed position than at in-bed position.
- (3) The combustion efficiencies according to the excess air ratios show the same tendency regardless of the position of CWM injector, as long as the fluidizing velocity is kept low.
- (4) As the preheat temperature of combustion air increases, the combustion efficiency does not change considerably, although the unburned carbon contents in the elutriated ash decrease.

ACKNOWLEDGMENT

This study was supported by Korea Science and Engineer-

ing Foundation (KOSEF). The authors wish to acknowledge the financial aid during the course of this investigation.

REFERENCES

- Arana, U., et. al., 1984, "Coal-Water Slurry Utilization in Fluidized Bed Combustion", Pro. 6th Inter. Symposium on Coal-Slurry Combustion and Technology.
- Beer, J.M., et. al., 1985, "Fundamentals of Coal-Water Fuel Droplet Combustion", Ichem F Symposium Series, No. 107, pp. 179~194.
- Cen, K., et. al., 1985, "Pipeline Conveyance Fluidized Bed Combustion of Coal Water Mixture with High Viscosity", Pro. 2nd European Conference on Coal Liquid Mixture, pp. 87~99.
- Cen, K., et. al., 1986, "Design and Operation of a 10 t/h Steam Boiler with CWS-FBC Technology", Pro. 8th Inter. Symposium on Coal-Slurry Fuels Preparation and Utilization, pp. 568~576.
- Kim, D.C., et. al., 1984. "Preparation and Combustion of CWM of KIER Experimental Facilities", Pro. Coal Utilization Technology, 1st Korea-U.S.A. Joint Workshop, pp. 131~157.
- Rowley, D.R., et. al., 1985 "Fluidized Bed Combustion of Coal Water Slurry", Pro. 7th Inter. Symposium on Coal-Slurry Fuels Preparation and Utilization, pp. 612~627.
- Patricia, L.M., et. al., 1984, "The Mechanism of Combustion of Coal Water Slurries", 20th Symposium on Combustion, The Combustion Institute, pp. 1409~1418.
- Philipp, J., 1984, "Coal-Water Slurry : a Substitute Fuel in Oil-Fired Boilers", Pro. Coal Utilization Technology, 1st Korea-U.S.A Joint Workshop, pp. 111~123.
- Poersch, W., 1979, "Wirbelschicht ver Brennung von Schwierigen, Ballastreichen Brennstoffen", VDI-Berichte Nr. 346.
- Water, P.L., 1975, "Factors Influencing the Fluidized Combustion of Low Liquid and Solid Fuels", Inter. of Fuel Symposium, Ser. No. 1 ; Fluidized Combustion.